



The mission of St. Paul's Episcopal Church is to worship God
and to bring all into a loving relationship with Jesus Christ

December 2008

Edition 8 - Volume 12

www.stpaulsmboro.org

Looking Back and Living Forward

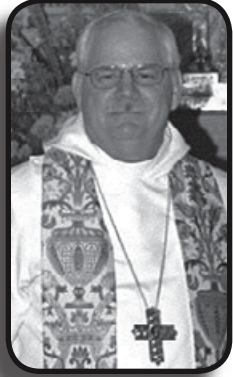

*Time present and time
past
Are both perhaps present
in time future,
And time future contained
in time past...*

These are the opening words of the first quartet of T.S. Eliot's classic, "The Four Quartets."

And so he launches his exploration of what it means for us to live in a changing, imperfect world as beings who can occasionally catch glimpses of grace, the sacred, invisible reality that is behind, and at the heart of, all things. We live in the present, but unlike other animals, we are also conscious of the past and future.

The season of change that is upon us is one of those intersections of time past and time future. St. Paul's has just completed a long season of discernment. I know that the knowledge gained and the lessons learned will be used for God's glory. I also know that in the coming years, in the rhythm of our lives together, in the good times and in the bad, in our shared joys and sorrows, we will indeed catch more than our fair share of glimpses of grace. That is because you are an extraordinary parish. For allowing us to be a part of you I will be forever grateful.

Ecclesiastes 3 offers a litany of the actions of our everyday life and their opposites: "To everything there is a season, and a time for every purpose under heaven..."

I find myself doing a lot of self-reflection during these days that symbolically bridge the past, present, and future. And what I

have found is that I am glad for cycles of beginnings and endings. I am glad for the renewed strength that comes from these seasons of change, between what has been and what is yet to be. This is a time that offers a chance for self-assessment, for soul searching, an opportunity for those old practices of confession and forgiveness. It is a time for tying up the loose ends, cleaning house (figuratively and literally!), and starting anew.

As I look back, I try to see what I have learned while also facing the rising sun of a new season. This is a time where I would be wise to linger for a moment, to step outside of time, pausing to take stock of the spiritual work I need to attend to. In the words of Ecclesiastes, this can be a season in my own soul of casting away and gathering up, of uprooting and planting, of dying and of giving birth.

The last stanzas of T.S. Eliot's "The Four Quartets," say it best:

*What we call the beginning is often the end
And to make an end is to make a beginning.
The end is where we start from...
And all shall be well and
All manner of thing shall be well....*

My prayer is that this time of endings and beginnings will be a time of explorations of the heart and journeys of the soul for each one of us. May we all remember the One who is the source of life and all love as we move into the future. And may you stand firm in the knowledge that ...all shall be well and all manner of thing shall be well....

Polk+

~ **LESSONS AND CAROLS** ~
Sunday December 7, 4:00 p.m. ~ Reception Following

THE
E
V
A
N
G
E
L

A MONTHLY
NEWSLETTER
PUBLISHED BY

ST. PAUL'S
EPISCOPAL CHURCH,
MURFREESBORO, TN

Advent: Then, Now, and To Come

By Kathleen Jayco

Advent serves as a dual reminder of the original waiting that was done by the Hebrews for the birth of the Messiah as well as the waiting that Christians today endure as we await the second coming of Christ.

Whenever someone mentions the second coming, my mind immediately brings forth a favored poem by W.B. Yeats—aptly titled, *The Second Coming*. The poem was written to reflect what was happening with the Russian Revolution—a chaotic time in history for sure:

*Turning and turning in the widening gyre
The falcon cannot hear the falconer;
Things fall apart; the centre cannot hold;
Mere anarchy is loosed upon the world,
The blood-dimmed tide is loosed, and everywhere
The ceremony of innocence is drowned;
The best lack all conviction, while the worst
Are full of passionate intensity.
Surely some revelation is at hand;
Surely the Second Coming is at hand.*

*The Second Coming! Hardly are those words out
When a vast image out of Spiritus Mundi
Troubles my sight: somewhere in sands of the desert
A shape with lion body and the head of a man,
A gaze blank and pitiless as the sun,
Is moving its slow thighs, while all about it
Reel shadows of the indignant desert birds.
The darkness drops again; but now I know
That twenty centuries of stony sleep
Were vexed to nightmare by a rocking cradle,
And what rough beast, its hour come round at last,
Slouches towards Bethlehem to be born?*

You don't have to look hard to see things falling apart these days---the financial world, political bickering, international strife. The picture Yeats paints in his poem might as well have been written about today!

This Advent season the state of the world weighs heavily upon my heart. Now more than ever I pray for the world and look to the future coming of Christ and His heavenly kingdom for hope and peace. The line that most strikes a chord with me: "The best lack all conviction, while the

worst / Are full of passionate intensity." What could be more horrible than a world in which the best people stop caring and the worst proclaim their messages of hatred unfettered?

But it doesn't have to get that way. As a woman in her early-20s, I believe my generation can breathe new life into the world. Even if I stand alone in my convictions for peace and love, I still stand. Call me a hippie, call me a commie, call me whatever you want---but you can't say that I don't care.

Yeats, in case you are unfamiliar, was a pretty weird guy. He was fascinated by mystical Christianity and the occult (and I'll admit to similar fascinations myself). The concluding lines refer to Yeats' belief that history was cyclic, and that his age represented the end of the cycle that began with the rise of Christianity. There's a certain sense of fear and wonder with these lines---what will happen when it's all said and done?

Continued on page 6



Musical Notes

The St. Paul's Choir and Choristers will present a Service of Lessons and Carols on Sunday, December 7, at 4:00 p.m. Patterned after the traditional service from King's College, Cambridge, the afternoon will feature choir anthems and congregational singing accompanied by brass quintet. The service is free, and a nursery is provided. A reception will follow in Parish Hall.

The Nashville Chamber Singers, under the direction of Angela Tipps, will perform a Christmas choral concert on Tuesday, December 9, at 7:30 p.m. Selections include Latin motets, carols from Spain, Italy, and France, as well as some secular favorites. The concert is free, and a nursery is provided.

During the four Sundays in Advent, we will hear selections from Handel's *Messiah* during the 11:00 worship service. They include "But who may abide" sung by Brooke Hazen, mezzo-soprano, "Comfort Ye" sung by Stephen Smith, "Rejoice Greatly" sung by Cayce Stephens, and the chorus "And the Glory of the Lord."

The Progressive Dinner

THANK-YOU

THANK-YOU THANK-YOU!

The Progressive Dinner, held Friday, November 7, was attended by nearly 100 people and chaired by Jeannie Roberts. Kudos to you, Jeannie! After salad and main dish courses in about 18 different homes, we gathered at the home of B.J. Huggins for the dessert course to end the evening. Serving as co-hosts with BJ were Newton and Charlotte Molloy. Thank-you! The lovely setting was made even more special because as a church family, we celebrated B.J.'s birthday with her. Thank-you to all the home hosts! It was a wonderful night.

On Sunday, November 9, following the Consecration Sunday service we gathered for lunch at the Stones River Country Club. Special thanks to Bill Jones who made the arrangement for us there after we learned the James Union Building was booked. Special thanks go to Betty Davis who handled all the details of the luncheon with the club; DeeDee Tidwell, Arlene Shoemaker and Marcie Richmond who made all the table decorations.

LESSONS AND CAROLS

RECEPTION

Every year following Lessons and Carols there is a lovely reception honoring our wonderful choir, complete with fabulous holiday goodies, in the Parish Hall. This year is no exception, but it will be made ever-so-much-more special by the fact that we will be welcoming Rev. Polk and Mary Jo Van Zandt into our midst at the same time! Please join your Vestry that evening, December 7, in welcoming them as part of God's community here at St. Paul's Murfreesboro! As always, there is a signup sheet in the Parish Hall because we depend on YOU, our wonderful cooks, to prepare the delicious repast. Sign up for an appetizer, sweet tray or finger sandwiches and indicate how many will be in your party so we can anticipate quantities of beverages. We ask that you bring your food, table-ready on nice serving piece, to the Parish Hall no later than 4:00 p.m. that afternoon. If you have any questions please feel free to call Kathleen Herzog at 497-9652 or Marcie Richmond at 890-7812. It will be spectacular!!

Toddlers to Teens...



Christmas Pagaent 2008

One of our many wonderful traditions at St. Paul's is the annual Christmas Pagaent. The touching story of Jesus' birth is retold so that children (and adults) can be reminded of the true gift.

This year, we look forward to an original work written by chair Patricia Petty, along with music from our Choristers and the opportunity for the congregation to sing some favorites of the season.

Lots of children...that's what we need to make the pagaent wonderful! We also need a few adult volunteers to help with rehearsals, costumes, and activity management.

Rehearsals will be Saturday, December 6 and 13, at 10:00 a.m., and Sunday, December 21, at 3:00 p.m., in the Nave.

If your children or grandchildren would like to participate in this year's pagaent, please plan to bring them to the rehearsals. There are parts, big and small, speaking and non-speaking, for many children, from toddlers to teens.

A Christmas Blessing

May you have the Spirit of Christmas, which is Peace,
The Gladness of Christmas, which is Hope, The Heart of
Christmas, which is Love, The Gift of Christmas, which is
Christ. —Ada Hendricks

I was fortunate to receive training for Level II of Catechesis of the Good Shepherd (CGS) from Carol Nyberg - one of three instructors during my course. Carol was one of the few people who actually trained in the United States over 25 years ago with Sofia Cavalletti, the creator of CGS. She continues to work in the CGS program, has been active in the National Association and is currently working on her Masters in Pastoral Studies, with an emphasis on Catechesis of the Good Shepherd, through Aquinas Institute of Theology in St. Louis. Below you will find an Advent reflection penned by her daughter. Kirsten, now grown with a child of her own, grew up immersed in the culture of CGS. I believe the reflection is exactly that - a wonderful reflection of the fruits of the work of CGS. I hope you enjoy it as I have. - Libby Willis

An Advent Reading

I was asked this year to write an Advent reading about a time I was waiting for God. However, when I sat down to brainstorm, I found it difficult to remember such a time.

I thought first of the summer my father died, trying to recapture my nine-year-old spiritual journey. Did I feel I was waiting for God? Did I feel lost, abandoned, angered? It would be much easier to say "yes... where was God then?" but in truth, I felt no separation from Him. God was the Frisbee that allowed my brother and I to bond in the backyard, silently understanding that we'd always be there for one another. He was the numerous casseroles, cakes and loving friends that showed up at our doorstep to nourish us until we could nourish ourselves. God was in every multi-colored marker used by my 2nd grade class to make me sympathy cards. To me, His presence was irrefutable.

But I'm supposed to write about waiting, I thought, and so I kept digging. Perhaps sometime in high school? College? In my more rebellious stages, was I waiting for God to find me again?

When I was confronted with choices far beyond my capacity, responsibilities too weighty for my youth, did I feel as though God had gone missing? Put simply, no.

I knew God was the voice in my head telling me the truth, whether I listened or not. He was the silly games I played at youth group, reminding me that I was still a kid and life wasn't always a struggle. If I turned away, He waited patiently for me. When I pulled Him close, He was more comforting and peaceful than I thought possible.

In truth, I cannot think of a single instance in life where I have had to wait for God. This, to me, is the joy of Advent. It is a symbolic time of preparation for the God that is ever-present. The birth of Christ made it possible for us to never wait for God again. Christ wasn't born. Christ is born. Always. During Advent we celebrate Christ's continual coming into the world, arming ourselves with the hope and gratitude particular to this season. Let us prepare ourselves! Christ is born!

-Kirsten Nyberg

CATECHESIS

of the Good Shepherd

Advent is a time to celebrate Jesus' birth, to give thanks for His presence in the Word and the Sacraments, and to anticipate His second coming. For the children of Catechesis of the Good Shepherd, the schedule is packed during this joyous, expectant season. The Good Shepherd statue is removed from the prayer table and replaced with a sculptural prophet - his arms and face raised to the heavens. Messianic prophecies are read and transformed into song.

The people who walked in darkness have seen a great light

The people who walked in darkness have seen a great light

Come, Lord Jesus, come, Lord Jesus, come Lord Jesus, Come and be born in our hearts.

Come, Emmanuel, Come, Emmanuel, Come Emmanuel, come and be born in our hearts.

Wonderful Counselor, wonderful Counselor, wonderful Counselor, come and be born in our hearts.

Come, O mighty God. Come, O mighty God. Come, O mighty God, come and be born in our hearts.

Everlasting Father, everlasting Father, everlasting Father, come and be born in our hearts.

Come, O Prince of Peace. Come, O Prince of Peace, come and be born in our hearts.

Each week, as the candles of the Advent wreath are lit, this song is sung, adding a new verse each week.

Light one Candle for Hope, One bright candle for Hope

He brings Hope to every heart, He comes, He comes!

Light one candle for Peace, One bright candle for Peace

He brings peace to every heart, He comes, He comes!

Light one candle for Joy, One bright candle for Joy

He brings Joy to every heart, He comes, He comes!

Light one candle for Love, One bright candle for Love

He brings Love to every heart, He comes, He comes!

Advent is a time to look back in order to look forward. We look to God's word in the book of Luke. The angel Gabriel spoke God's words to Mary and she was ready to respond - "Here am I, the servant of the Lord; let it be with me according to your word." (Luke 1:38) Though the angel spoke only to Mary, God's word is shared with all through Jesus. We read of Mary's visit with her relative, Elizabeth, whose unborn son does not hesitate when he recognizes his Savior. In his mother's womb, he leaps with joy. Known to all as John the Baptist, he shared God's word with all he met. On the night of Jesus' birth, the shepherds were ready to respond, leaving their fields to join Mary and Joseph to adore the baby Jesus and share the word of God.

This season of anticipation empowers us to respond to God's love, His gift of His only son. What a joyous beginning to another new year. He comes!

Annual Men's Retreat

Coming February 27-28
Dubose Conference Center

After a year's hiatus, the Men's Retreat returns in 2009.

This year we will be gathering at Dubose on Friday evening, February 27, to share fellowship and then to watch the movie

The Bucket List

a story of two men exploring the meaning of life at the approaching end of their lives. On Saturday we will explore what the movie is saying to us in the context of our own busy lives. The retreat will end Saturday afternoon. Registration forms will be available beginning in December. Until then, put these dates in your schedule and plan to be with us and to invite another friend, newcomer, or guest.

Mark your calendars now !!!

St. Paul's Birthday Luncheon

December 11th at 11:30

If anyone has turned 70 this year and would like to join the Birthday Club, we would love to have them. Call Peggy Seneker for more details.

Weight Watchers

Weight Watchers will meet on Wednesday, December 3rd in the Parish Hall from 5 - 6 p.m. This meeting will be open to anyone interested in experiencing our meeting.

Our new 10 week series will begin on 12/10. Payments will be collected on 12/3 & 12/10 for the new series. We must have 14 paying members to continue our meetings at St. Paul's, so please spread the word. Current members will pay \$105; new members pay \$110.00; lifetime \$100. Credit cards payments are accepted or you may pay by check (one check for the full amount or two checks split evenly, dating one 12/10 & the 2nd 1/10).

For more information, please contact Libby, 545-0220.

Advent, Then, Now and... *Continued from page 2*

Obviously we know what happened—life went on, and continues to go on. The best part of coming into our own during this time is that, as long as we pay attention, we will have the knowledge and experience to not let it happen again. Or at least know what not to do... only time will tell.

We yearn for deliverance from the tyranny of the injustice we witness every day, echoing the cries of the Israelites in their time of bitter oppression. Yet we have the hope of deliverance by a God who has heard our cries—and this hope, however faint, and that God, however distant He might at times seem, brings with it the anticipation of that One who will rule with truth and justice and bring peace to all nations of the earth.

Advent is also a spiritual journey for individuals and congregations. We affirm, together, that Christ has come, that He is present in this crazy world today, and that He will come again. We are reminded of our call to be faithful stewards of the world God has entrusted to us. This Advent season we come together in a time of political and social unrest to celebrate the Incarnation and anticipate the future consummation, and with that celebrate our responsibility as a people called to love the Lord our God with all our hearts and love our neighbors as ourselves.

Stephen Ministry



*For this is the message
you have heard from
the beginning, that we
should love one another.*

1 John 3:11

St. Paul's has a new Website

Over a year ago the Vestry commissioned a communications committee to develop a new website. The committee focused on three target groups in designing the new website. First, the website would be informative and inviting to people who have little or no experience in church. Second, it would appeal to new members of our community who are looking for a church. And finally, it would help our current members in the conduct of their church ministries. On November 12, the new website went online.

In this day of increasing use of technology, the Vestry felt it important that St. Paul's have a substantial web presence. The website has two major areas. The first area is unsecured. This section is more specifically directed towards newcomers but has significant information available to our members without logging in. In the "What's Happening" section, you can see the entire church calendar online, including serving schedules for acolytes and lay Eucharistic ministers. If you want to review a bulletin announcement from this week or last, you can find it here as well. You can even find every back issue of the Evangel for the last two years here. If you want to be inspired by some recent offerings from the choir, you can find those in the "Sight and Sound" section. You can take a trip down memory lane in our photo album. Let's say you need to make a document available for members of the church to view or download. You can have it posted by the webmaster in the "downloads" section of "Sight and Sounds" for others to see.

St. Paul's is very interested in keeping our member information up to date. Our website allows you access to the most current information about membership through our online mirrored

database called AccessACS. This section allows you to update your personal information in one place and have it immediately updated with every committee or ministry in which you participate. Say your phone number changes and you are in the choir, on the Altar Guild, and participate in Ladies Night Out. If you update your personal info in AccessACS, each of these committees will automatically have the right information. Say you are a ministry team leader and wish to send an email to your team. Go onto AccessACS and shoot the email to your targeted group. It will always go to the most current email address without your having to change a thing.

Although not available yet, in the future if you wish to access your contribution information for the year, that will be done in AccessACS as well. You can retrieve only your own financial information. No one else will be able to access that, not even the administrator of the website. In the future we will have the ability to allow you to register for events online and even pay for events or pledges online. These features will be for your convenience. If you do not wish your personal information to be accessible to other members, you may restrict any or all access to your personal information. There are no social security numbers in our database, so the only identity information available online is what is already available in the phone book.

We view the Internet as a valuable tool to do God's work. We are constantly seeking ways to make better use of the means at our disposal. We hope that you will visit your new church website often and make use of the valuable tools on AccessACS frequently.

OUTREACH...A Sign of God's Love in the World

In the beginning was the Word, and the Word was with God, and the Word was God. He was in the beginning with God. All things came into being through him, and without him not one thing came into being. What has come into being in him was life, and the life was the light of all people. The light shines in the darkness, and the darkness did not overcome it... And the Word became flesh and lived among us, and we have seen his glory, the glory as of a father's only son, full of grace and truth. --John 1:1-5, 14

These familiar and beautiful words, which we hear on Christmas, remind us that God became one of us, joining us in the darkness of the world to bring light and warmth and life to all. As Christians, we embody that light for the world to see as a sign of God's love for His children. We have been told elsewhere in Scripture that whenever we serve the least of

God's children, it is a sign of Christ's presence among us.

In the season of giving and receiving presents, let's take time to remember and recognize the Presence that is our most precious gift. So many of God's children go hungry this winter or shiver in the cold. Reaching out to those who are needy at this time is a sign of the Life that gives us life. Let Christ's light shine through you in the darkness—it will not be overcome.

This month, on Sunday the 14th, we will collect warm clothing to distribute to Greenhouse Ministries, the Family Resource Center and the Salvation Army. There will be several collection bins in the Parish Hall beginning on Sunday the 7th. Please bring gently used or new items such as hats, gloves, scarves, sweaters, jackets, coats and boots on those days. Thank you and God bless us, everyone!

St. Paul's Youth

Christmas Party

Sunday, December 14th

Join us for a fun-filled night that includes bowling, a gift-exchange, games and food!!
Check out the website for more details including cost and times!

A central graphic for a ski trip. It features a central rectangular box with a jagged, sawtooth border containing the words "SKI TRIP" in a bold, blocky font. The box is flanked by two stylized, black-and-white line drawings of people skiing down a slope. The figures are simplified, showing skis, poles, and a mountain peak in the background.

SKI TRIP

January 23rd – 25th
Paoli Peaks, IN

Join us for this awesome weekend!!!

We'll be staying in a lodge RIGHT ON THE SLOPES
so you can ski right into the lodge if you need to take a break or get hungry!!

Trip Cost: \$195*

**the cost is all-inclusive AND gets cheaper
the more people sign-up (so tell everyone)*

Go to www.stpaulsyouthonline.com for more details.

Yuletide



Enjoy the Christmas season with these games, centered around the theme of Jesus, our greatest gift.

JESUS' BIRTH FROM A-Z

What you need:

- Paper
- Pencils or pens
- Bibles (optional)



What you do:

Instruct players to think of as many Christmas-related words as they can that start with each letter of the alphabet. Start with A and give everyone a minute to brainstorm words for each letter. For example, M words include manger, Mary and miracle. If you get stuck, look at the Nativity accounts in Matthew 1 and 2, and also Luke 2. Players get a point for each word not repeated by others.

PIN THE STAR ON THE MANGER

What you need:

- Butcher paper, poster board or plain wrapping paper
- Markers, paint or crayons
- Construction paper stars
- Tape
- Blindfold



What you do:

On large paper, draw a picture of a stable. Give each player a star cutout. Put a small + above the manger where the star led the shepherds and wise men to baby Jesus. Like in Pin the Tail on the Donkey, the blindfolded person who puts his or her star closest to the + wins.

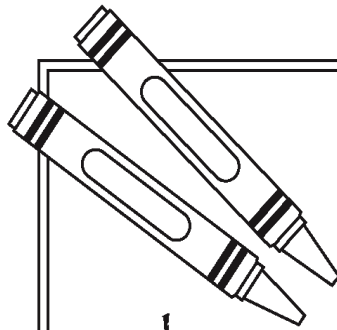

The Story of Jesus' Birth

Jesus' birth is recorded in three New Testament chapters: Matthew 1 and 2, and Luke 2. Follow some important words about our Savior's birth by starting at a word beginning with the letter A and finishing with a word starting with the letter Z.





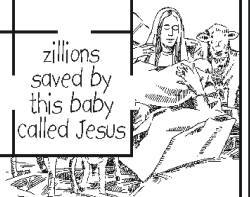









angels	Bethlehem	car	dance	easel	
cat	bear	child	donkey	egg	fast
holy	glory	flocks	Earth	feathers	gap
inn	jacket	grapes	peace	quiet	hat
Joseph	king	Lord	only	righteous	shepherds
kelp	loop	Mary	night	unique	tidings
last	maze	paper	wise men	virgin	water
open	nest	word	excitement	young	zillions saved by this baby called Jesus



Answer: angels, Bethlehem, child, donkey, Earth, flocks, glory, holy, inn, Joseph, king, Lord, Mary, night, only, peace, quiet, righteous, shepherds, tidings, unique, virgin, wise men, excitement, young, zillions (saved by this baby called Jesus)

DECEMBER 2008

Sun	Mon	Tue	Wed	Thu	Fri	Sat
	1 11:30 am Staff Meeting 4 pm Christmas Tea 5:30 pm Alanon 6 pm Girl Scouts 6:30 EFM 7 pm AA 	2 9 am Recital Rehearsal 4 pm RSCM Rehearsal 6:30 pm Cub Scout/Bears 7 pm Bible Study 7 pm AA 	3 7 am & 5:30 pm HE 9 am Bible Study 5 pm Weight Watchers 6:30 pm D-Groups/Youth 7 pm AA 7:15 pm Choir Rehearsal	4 6 pm Ladies Night Out 6 pm Men's Club 6:30 pm Stephen Ministry Training at Holy Cross Murfreesboro 7 pm AA	5 7 pm AA	6 9 until 11 am Craft & Bake Sale drop off 10 am Christmas Pageant Rehearsal 5:30 pm Morris/Recital 7 pm AA
7 Advent 2 7:30, 8:45 & 11:00 am HE 8:45 am Children's Church 9:55 am Christian Education Craft/Bake Sale after all services 4 pm Lessons and Carols Following with a Welcome Recept. for Rev. Polk and Mary Jo 5 PM Xperience/Youth 	8 11:30 am Staff Meeting 5:30 pm Alanon 6:30 EFM 7 pm AA 	9 12 pm Morning Side Delivery NO RSCM Rehearsal 6 pm Vestry Meeting 6 pm Catholic Charities of Nash. 7 pm Bible Study 7 pm AA 7:30 pm Chamber Singers V	10 7 am & 5:30 pm HE 9 am Bible Study 5 pm Weight Watchers 6:15 pm Outreach 6:30 pm D-Groups/Youth 7 pm AA 7:15 pm Choir Rehearsal	11 11:30 am Sr. B'day Luncheon 6:30 pm Stephen Ministry Training at Holy Cross Murfreesboro 6:30 pm Cub Scout Pk108 Com Mtg. 	12 5:30 pm AA Pottluck 7 pm AA	13 10 am Troop Support Pkrg Prep. 10 am Christmas Pageant Rehearsal 2 pm Group Event 7 pm AA 
14 Advent 3 7:30, 8:45 & 11:00 am HE 8:45 am Children's Church 9:55 am Christian Education 12 pm Parents' Day Out 5 pm Dream Group 5 pm Xperience/Youth 7 pm AA Warm Clothing Drive 	15 11:30 am Staff Meeting 11:30 am Rutherford Count Christmas Party 5:30 pm Alanon 6 pm Girl Scouts 6:30 pm EFM 7 pm AA 	16 4 pm RSCM Rehearsal 6:15 pm Dreams 6:30 pm Cub Scout Troop/Bears 7 pm Bible Study 7 pm AA 	17 7 am & 5:30 pm HE 9 am Bible Study 5 pm Weight Watchers NO D-Groups/Youth 7 pm AA 7:15 pm Choir Rehearsal	18 6:30 pm Stephen Ministry Training at Holy Cross, Murfreesboro 7 pm AA	19 7 pm AA	20 6 pm Choir Christmas Party 7 pm AA
21 Advent 4 7:30, 8:45 & 11:00 am HE 8:45 am Children's Church 9:55 am Christian Education 3 pm Christmas Pageant Rehearsal 5 pm Dream Group NO Xperience (Youth) 7 pm AA 	22 11:30 am Staff Meeting 5:30 pm Alanon 7 pm AA 	23 4 pm RSCM Rehearsal 7 pm Bible Study 7 pm AA	24 CHRISTMAS EVE Church Office Closed 9 am Bible Study 4:30 pm Christmas Eve Service 5 pm Weight Watchers NO D-Groups/Youth 7 pm AA 10:30 pm Christmas Eve Service	25 CHRISTMAS DAY Church Office Closed 10:30 am Christmas Day Service 7 pm AA	26 Church Office Closed 4 pm McCash Rehearsal 7 pm AA	27 4 pm McCash Wedding/Reception 7 pm AA
28 First Sunday After Christmas 7:30, 8:45 & 11:00 am HE 8:45 am Children's Church 9:55 am Christian Education 5 pm Dream Group 	29 11:30 am Staff Meeting 5:30 pm Alanon 6 pm Girl Scouts 7 pm AA 	30 NO RSCM Rehearsal 7 pm Bible Study 7 pm AA	31 7 am HE NO 5:30 pm HE 9 am Bible Study 5 pm Weight Watchers 7 pm AA	NOTES/REMINDERS: <i>December 7, Lessons & Carols followed by a welcome reception for our new rector, The Rev. James K. Polk Van Zandt and Mary Jo</i> <i>December 7, Craft and Bake Sale after all three services</i> <i>December 14, Warm Clothing Drive</i> <i>The Church Office will be closed Dec. 24, 25 & 26th</i>		



Stephen Sachs 12/1	Gilda Hurst 12/16
Anastasia Kirkham 12/1	Michael Becker 12/17
Nicholas Sargent 12/1	Jonathan Bartsch 12/18
Nancy Sandvig 12/3	Jonathan Wilson 12/18
Alexia Luchtefeld 12/3	Mark Wakefield 12/20
James Boyd 12/5	Michael Elrod-Erickson .. 12/20
Michael Stewart 12/5	Nicole Vendur 12/21
Nathan Bedford Clemmons . 12/6	Allyson Davis 12/22
Fred Kinney 12/7	Aerolene Cox 12/23
Mitchell Mann 12/7	Janice Cole 12/24
Ron Messier 12/8	David Jones 12/24
Pamela Brown 12/8	Barry Huber 12/24
Glenda Webb 12/9	Sarah Carr 12/24
Angela Tipps 12/9	Robert Lynch 12/26
Edith Brophy 12/10	Lewis Williams 12/26
Thomas Washer 12/10	Carol Hanna 12/26
Dan Erickson 12/11	Olivia Carpenter 12/27
Eric Blum 12/11	Brian Burritt 12/28
Nicholas McGuire 12/12	Curtis Hanna 12/28
Billie Freitag 12/13	Robert Bray 12/28
Loretta Kimball 12/13	Carole Carroll 12/30
Brittany Whitmore 12/13	Denise Nunley 12/31
Sarah Ordoubadian 12/13	Melinda Haines 12/31
Kermit Davis 12/14	Charlotte Young 12/31

MEMBERSHIP RECORDS UPDATE

If you have moved, changed your home or cell phone numbers, or have had a change in your e-mail address, please contact the church office to update your records.

PUBLICATION DEADLINES

Announcements for the Sunday bulletin are due in the church office by Wednesday, 12:00 noon, each week.

Articles for the monthly Evangel newsletter are due in the church office by the 15th of each month.

The deadline for the January Evangel is Monday December 15, 2008. Please e-mail all information to evangel@stpaulsmboro.org.

PARISH STAFF

- The Rev. Matt Greathouse, Priest In Charge
- Chuck Phillips, Sr. Warden
- Joshua Courtney, Minister to Youth
- Susan Greenall, Office Administrator
- Dr. David L. Rowe, Assistant to the Rector
- Ralph Smith, Assistant to the Rector
- Joyce Adkins, Assistant to the Rector
- Angela Tipps, Minister of Music
- Jacob Courtney, Assistant Minister to Youth
- Aimee Spurlock, Choirmaster RSCM
- Kathy Warlick, Administrative Assistant
- Kathy and Bill Jones, Co-Treasurers
- Annie Gracia, Nursery Director

VESTRY

- Wardens: Chuck Phillips,
- Rodney George, Jeff James, Bill Williams
- Kathleen Herzog, Kristi Hay, Barry Huber,
- Ron Messier, Robin Newell, Marcie Richmond,
- Fant Smith, Jane Smith

FELLOWSHIP OF OLDER FRIENDS
"Hilltoppers"

Older friends help each other when they need:

- Transportation • Visits
- Phone Calls • Help with Errands

We are eager to know of any parishioner who may have these needs OR if you are willing to provide some of these services.

– Call –

Jo Wintker at 907-5725 or Ralph Smith at 556-6414.

St. Paul's Episcopal Church

116 North Academy Street
 Murfreesboro, TN 37133

Church Office	615.893.3780
Office Fax	615.893.2892
Office E-mail	office@stpaulsmboro.org
Website	www.stpaulsmboro.org

St. Paul's Episcopal Church
116 N. Academy Street
Murfreesboro, Tn 37130

Return Service Requested

**NON-PROFIT
ORGANIZATION
U.S. Postage
PAID
PERMIT 189
Murfreesboro, TN**

MARK YOUR CALENDARS

Our next Ultreya will be Sunday, January 18, after the 11:00 service.

A gathering of Christian friends, potluck lunch, music.

December 2008



Q. *Why do you go to church?*

A. Not an easy question, but a good one. I go because it prepares me for the week ahead.

Q. *How?*

A. I don't exactly know. It gives me a chance to be alone with myself, to do a little self-examination. I need a lot of that. It's a time of contemplation, a time of thinking about one's life; how it is; how it can be made better.

Q. *Any other reason?*

A. Oh, the homily. Does anyone realize what a parade of talent there has been through the St. Paul's pulpit? They are extraordinary.

Q. *And . . . ?*

A. Communion has a special meaning for me.

Q. *Why?*

A. I don't know . . . I mean there's the ancient metaphorical advisories, but beyond that. Communion is personal for me. Now, no more questions. This is mystical, but if church were not mystical, if one's religion didn't have some mystery then it wouldn't be a church. It would be Nissan Motor Company or Titans football. I embrace this mystery.